

WALL AT FOOT OF SLOPE

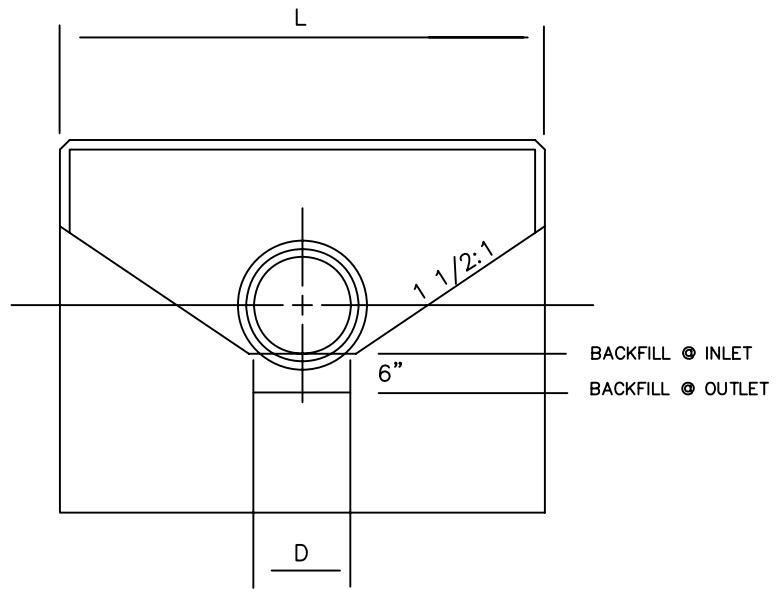

FRONT ELEVATION

NOTES:

1. ALL EDGES OF EXPOSED SURFACE TO BE CHAMFERED ONE INCH.
2. WHEN ONE ENDWALL IS TO BE USED FOR TWO PIPES, THE DIMENSIONS OF THAT ENDWALL SHALL CONFORM TO THOSE REQUIRED FOR THE LARGER PIPE, EXCEPT THE DIMENSION "L" SHALL BE INCREASED BY THE OUTSIDE DIA. OF THE SMALLER PIPE PLUS TWO FEET.
3. IF CONSTRUCTED ON FILL OR IN AN AREA OF OVER EXCAVATION, 8" OF PROCESSED AGGREGATE BASE SHALL BE USED.

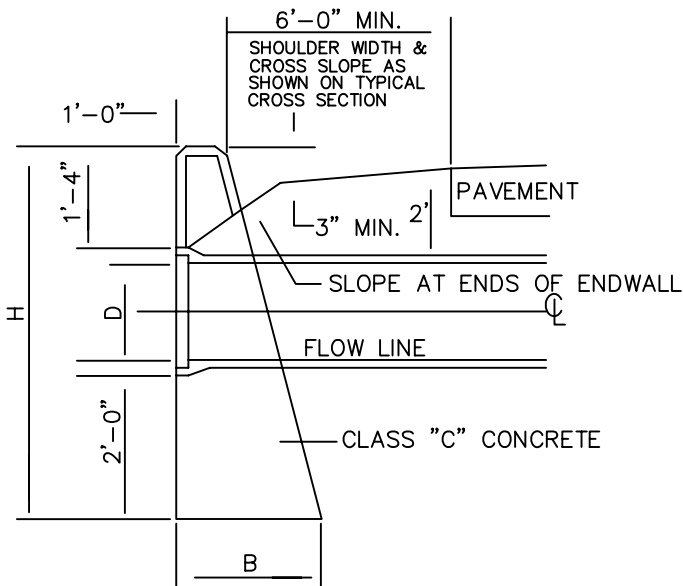

WALL AT SHOULDER

D= INSIDE DIA. OF PIPE
H= TOTAL HEIGHT OF WALL
L= LENGTH OF WALL=3S+D
B= BASE

ENDWALL DIMENSIONS				
D	H	L	BATTER PER FT.	B
INS.	FT.&INS.	FT.&INS.	—	FT.&INS.
12"	4'-6"	4'-6"	2 1/2"	1'-11 1/4"
15"	4'-9 1/4"	5'-6 3/4"		1'-11 7/8"
18"	5'-0 1/2"	6'-7 1/2"		2'-0 1/2"
24"	5'-7"	8'-9"		2'-1 1/8"
30"	6'-1 1/2"	10'-10 1/2"		2'-3"
36"	6'-8"	13'-0"	3"	2'-7 1/2"
42"	7'-2 1/2"	15'-1 1/2"		2'-9"
48"	7'-9"	17'-3"		2'-10 1/2"



TOWN OF WINDSOR
Engineering Department



ENDWALL
D-313



SCALE: HOR. NTS VER. DATE: MARCH 2009