

GRANITE STONE CURB AND
GRANITE TRANSITION AT DRIVEWAYS

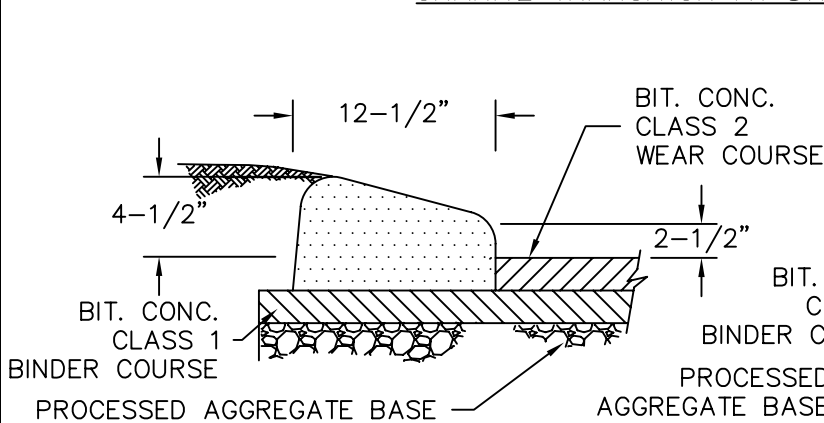

BITUMINOUS CONCRETE
CAPE COD CURB

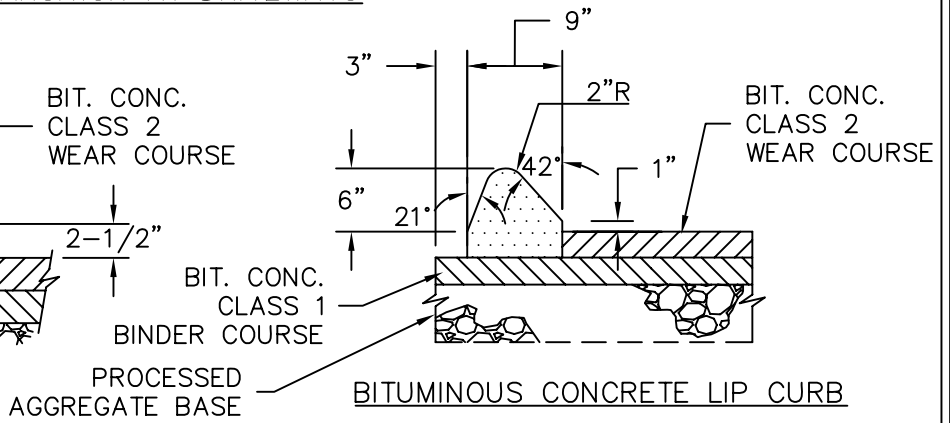

BITUMINOUS CONCRETE LIP CURB

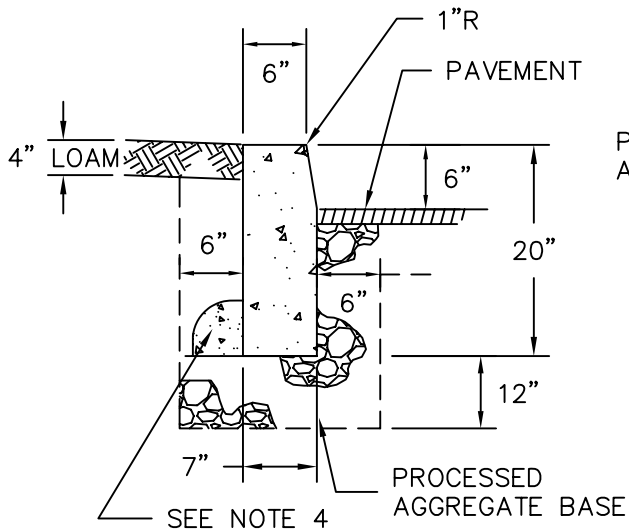

CONCRETE CURB

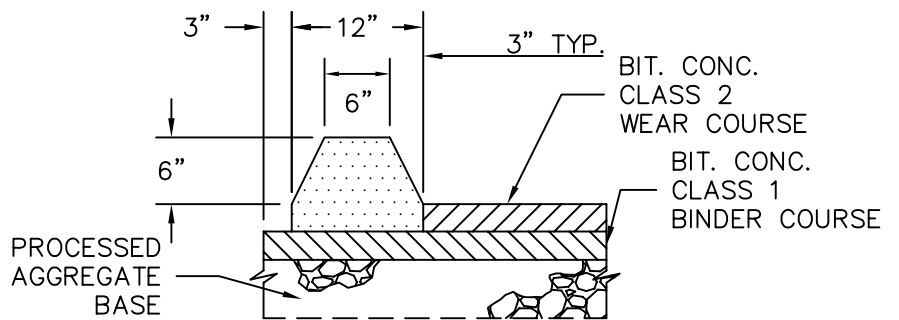

BITUMINOUS CONCRETE FLAT TOP CURB

NOTES:

1. MIN. LENGTH OF GRANITE CURB SHALL BE 4'-0".
2. GRANITE CURB FINISH SHALL BE SAWN TOP & SPLIT FACE JOINTED.
3. GRANITE CURB WITH A RADIUS OF 100' OR LESS SHALL BE BUILT OF CURVED GRANITE CURB.
4. CLASS "C" CONCRETE SHALL BE PROVIDED AS BACK SUPPORT TO FILL JOINT OPENING OF GRANITE AND CONCRETE CURBING AND AS BACK SUPPORT THROUGHOUT CURVED GRANITE AND CONCRETE CURBING, AS SHOWN.
5. A TACK COAT SHALL BE USED UNDER ALL BITUMINOUS CONCRETE CURBING.
6. MORTAR SHALL BE USED IN ALL JOINTS FOR CONCRETE AND GRANITE CURBING.



TOWN OF WINDSOR
Engineering Department



CURB TYPES
D-204



SCALE: $\frac{\text{HOR. NTS}}{\text{VER.}}$ DATE: MAY 2010